

MaxMotion

PERFORMANCE DATA SHEET

Meets or exceeds MEPS (Minimum Efficiency Performance Standards), as described by the US Department of Energy in docket 10CFR431 and Natural Resources Canada's Amendment 14

Catalogue #: **MPR-134CW**

HP	kW	Voltage	S.F. @ 60Hz	EFF.	P.F.	Frame	Design	L.R. Amps
0,33	0,25	575	1,15	72,0%	0,613	56HC	B	5

60 Hz								
FLA							Code	F.L. RPM
208	230	416	460	480	575	600		
/	/	/	/	/	0,56	/	L	1750

50 Hz								
HP	kW	FLA		S.F. @ 50Hz	Efficiency	P.F.	Code	F.L. RPM
		190	380					
/	-	/	/	/	/	/	/	/

Wgt. Lbs	PH	Duty	Insul. Class	Amb.	Elevation	Temp. Rise° C
22	3	Cont.	F	40°C	1000M (3300 Ft)	40

% Efficiency		% Power Factor		Torque		Winding Resist. Ω	Safe Cold Start (Secs)
Full Load:	72,0%	Full Load:	0,61	Full Load Ft/Lbs	1,0		
3/4 Load:	66,0%	3/4 Load:	0,57	Locked Rotor %	250		
1/2 Load:	52,3%	1/2 Load:	0,52	Break Down %	360	/	12

Rotor Inertia Wk2 Lb-Ft2	Max Load Inertia Wk2 Lb-Ft2	Shaft Material	Frame Material	DE Bracket Type	ODE Bracket Type	Enclosure	NEMA Rating	Lead Wire Size
/	/	Steel	Rolled Steel	Aluminium Alloy		TEFC	IP55	16AWG

Ball Bearings		Grease	Mount Type	Orientation	Paint	Sound Pressure @ 3FT	Sound Power
DE	ODE						
6205	6203	Sealed Bearings	Rigid	Horizontal	Black	/	/

Inverter Duty. Motor meets MG1 parts 31.4.4.2	Constant Torque Range	Variable Torque Range	Constant HP RPM
	10:1	20:1	2700

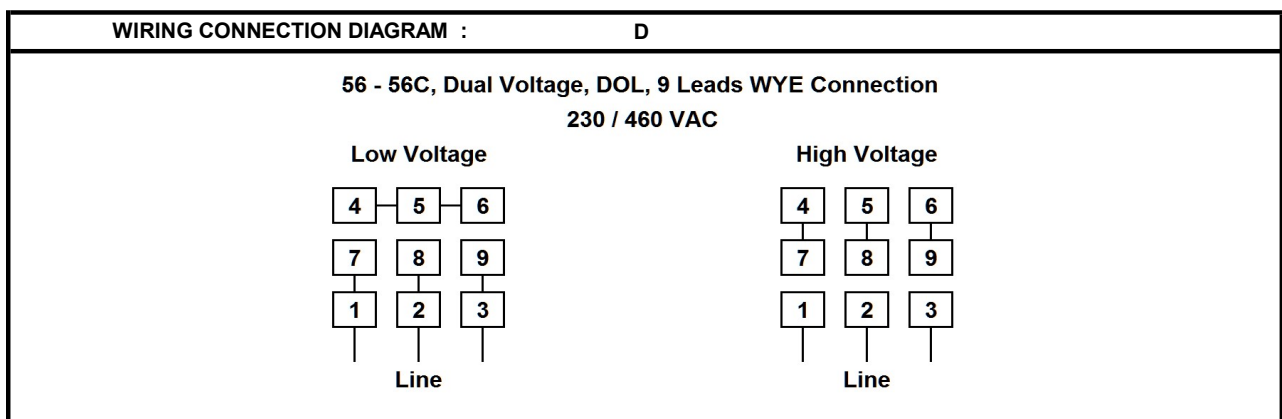

Date: 2023-12-21
 Customer: _____
 Contact: _____
 Submittee: J.C. Lavallée

Catalogue #: **MPR-134CW**

Meets or exceeds MEPS (Minimum Efficiency Performance Standards), as described by the US Department of Energy in docket 10CFR431 and Natural Resources Canada's Amendment 14

HP	VAC	RPM	Enclosure	Frame	Frequency	Design	Poles	LR Code Letter	Insulation Class	Temp. Rise °C
0,33	575	1750	TEFC	56HC	60	B	4	L	F	40
	0Hz	6Hz	15Hz	30Hz	45Hz	60Hz	75Hz	90Hz	105Hz	120Hz
Amps	0,56	0,56	0,56	0,56	0,56	0,56	0,56	0,56	0,56	0,56
RPM	0	175	437,5	875	1312,5	1750	2187,5	2625	3062,5	3500
Torq ft.lb	0,79	0,79	0,99	0,99	0,99	0,99	0,79	0,66	0,57	0,50
Peak Tq ft.lb	1,39	2,77	2,77	2,77	2,77	2,77	2,22	1,85	1,58	1,39
HP	0	0,0	0,1	0,2	0,2	0,3	0,3	0,3	0,3	0,3
	Locked Rotor	Pull-Up	Breakdown	Rated Load	Idle	Duty	S. F.	Ambient	Elevation	dBA @ 1M
Speed (RPM)	0,0	756	1440	1750	1800	Continuous	1,15	40°C	3,300 ft	/
Current (Amps)	5,0	4,3	3,0	0,6	0,4	VFD Rating: Meets MG1 parts 31.4.4.2				
Torque (ft.-lbs)	2,5	2,1	3,6	1,0	0,0	C.T.	10:1	V.T.	20:1	

Motor Speed Data

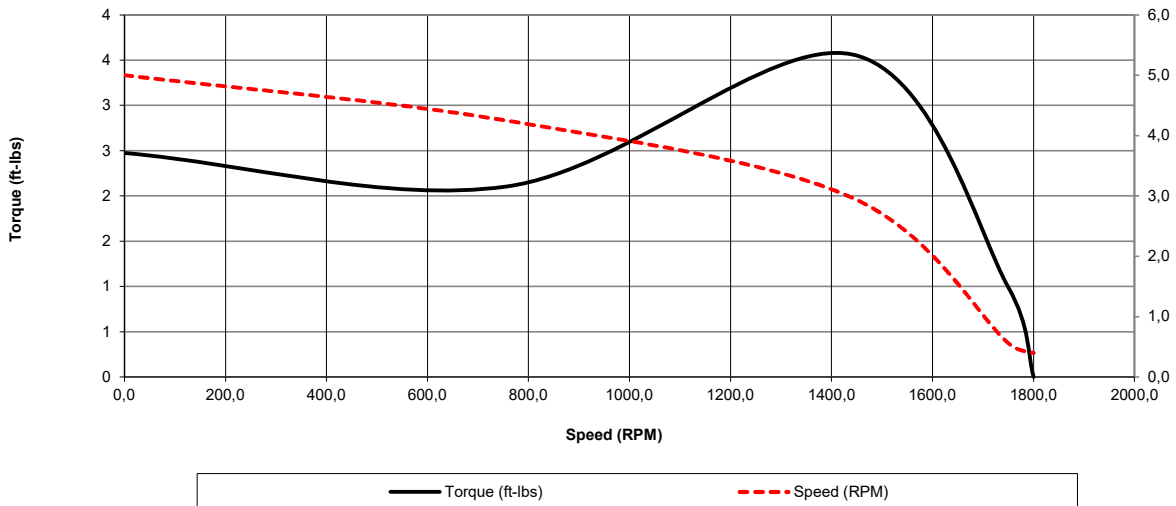

Motor Torque Capability vs RPM

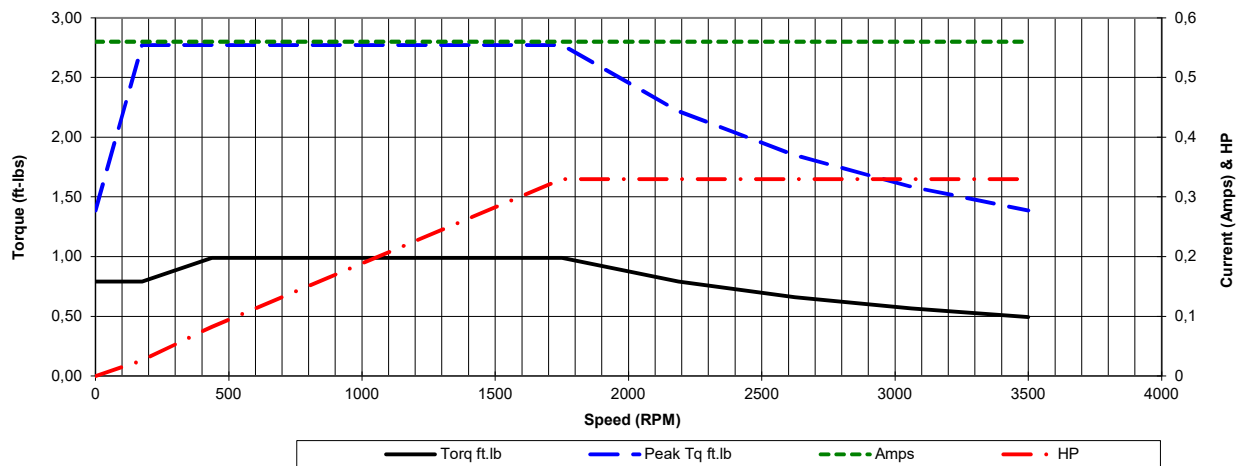



Date: 2023-12-21
 Customer: _____
 Contact: _____
 Submittee: J.C. Lavallée

Catalogue #: **MPR-134CW**

Meets or exceeds MEPS (Minimum Efficiency Performance Standards), as described by the US Department of Energy in docket 10CFR431 and Natural Resources Canada's Amendment 14										
HP	VAC	RPM	Enclosure	Frame	Frequency	Design	Poles	LR Code Letter	Insulation Class	Temp. Rise °C
0,33	575	1750	TEFC	56HC	60	B	4	L	F	40

Load %	0%	25%	50%	75%	100%	125%	150%
Amps	0,40	0,43	0,45	0,49	0,56	0,70	0,84
Torq ft/lbs	0	0,24	0,49	0,74	0,99	1,25	1,51
RPM	0	1787,5	1775	1762,5	1750	1737,5	1725
Eff	0	33,84	52,34	66,00	72,00	70,60	68,58
PF	0	42,9	52	57	61,3	62,5	64,4

	Locked Rotor	Pull-Up	Breakdown	Rated Load	Idle	Duty	S. F.	Ambient	Elevation	dBA @ 1M
Speed (RPM)	0	756	1440	1750	1800	Continuous	1,15	40°C	3,300 ft	/
Current (Amps)	5	4,3	3,0	0,56	0,3976	VFD Rating: Meets MG1 parts 31.4.4.2				
Torque (ft-lbs)	2,48	2,10	3,57	0,99	0,0	C.T.	10:1	V.T.	20:1	

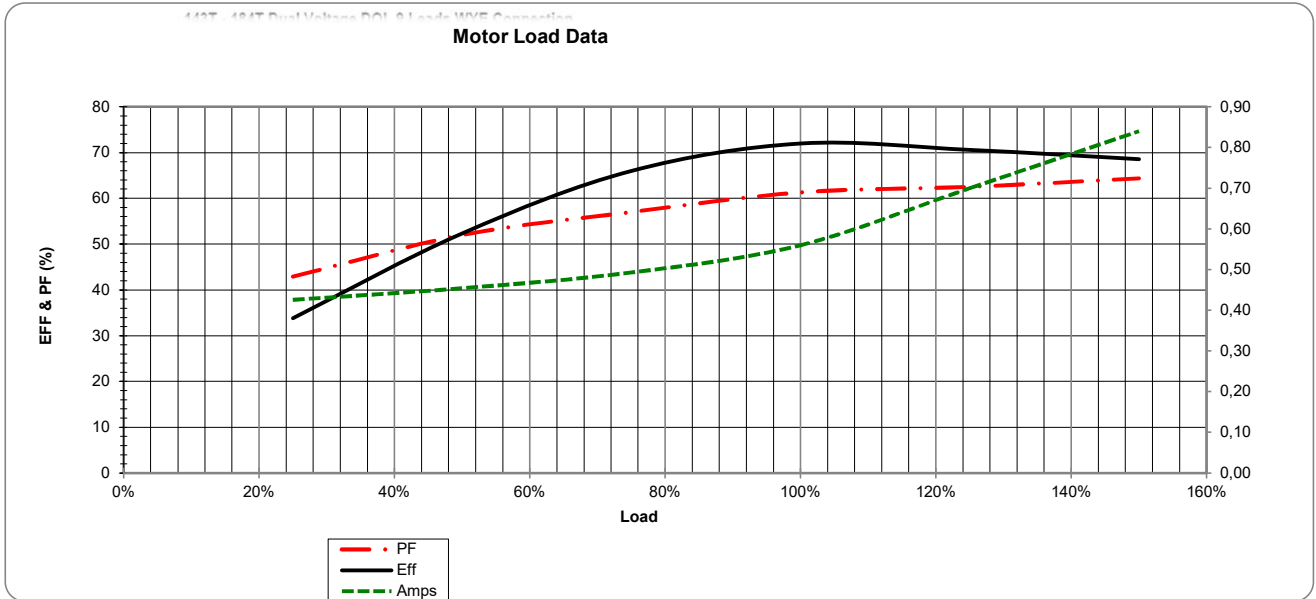
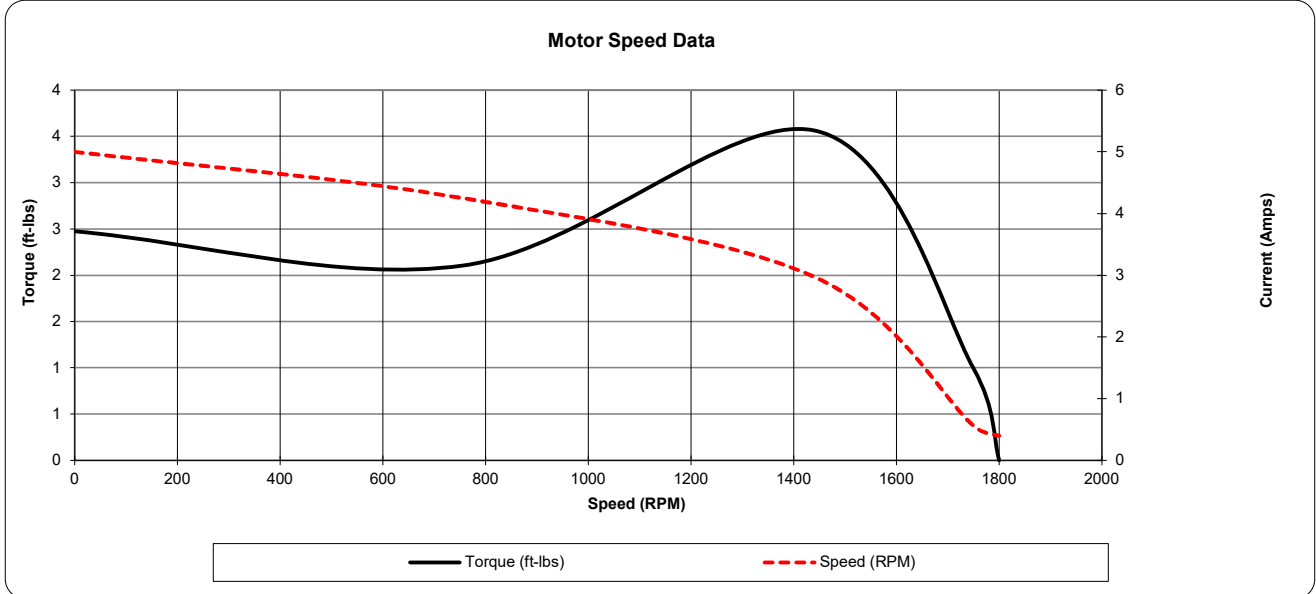

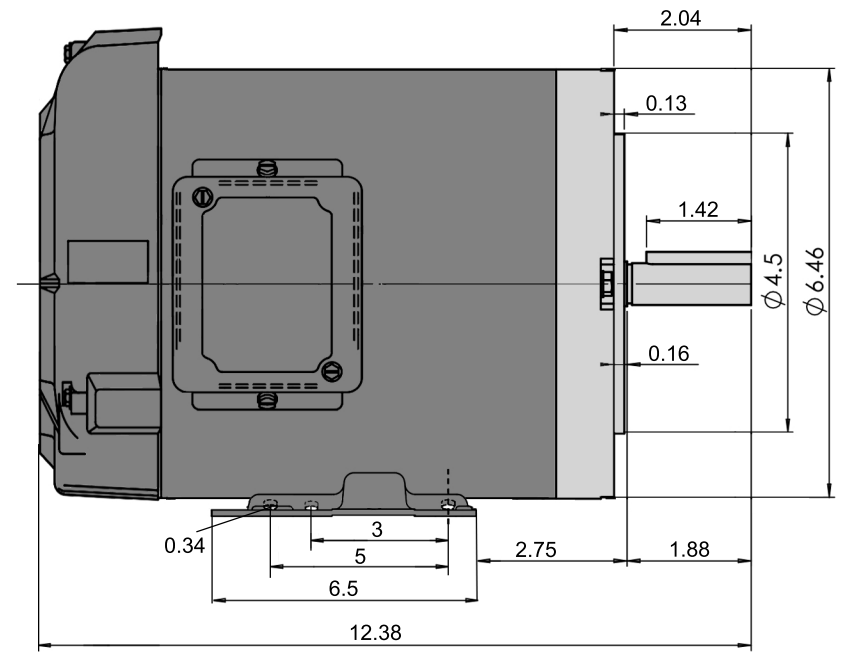
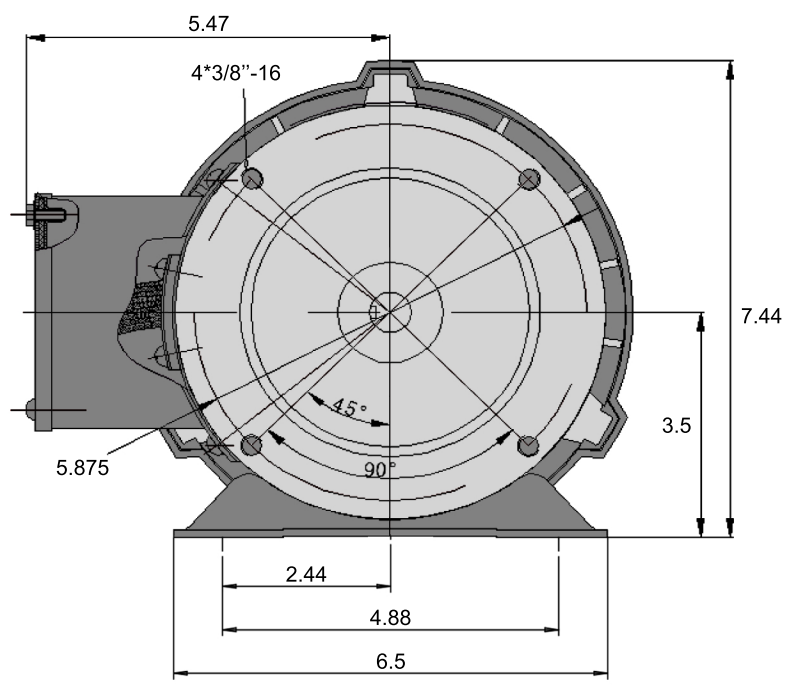
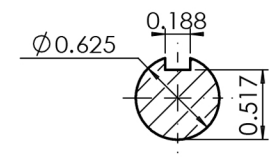

Version:1WEI	Revised: March 2024	HP	RPM	FRAME	ENCLOSURE
Customer is responsible in determining that MaxMotion product will fit/perform suitably in the intended application		1/3	1725	56CH	TEFC

MPR/MQR-134CW

THREE PHASE ALL-IN-ONE 56HC AC MOTORS

HEAVY GAUGE ROLLED STEEL CONSTRUCTION

TEFC TOTALLY ENCLOSED FAN COOLED | ALL-IN-ONE FRAME 56HC

MaxMotion

Applications:

A versatile design allowing replacement of C-Face or rigid base TEFC motors, for use on gear reducers, pumps, fans, blowers, conveyors, and all agricultural equipment requiring a motor to meet demanding high starting torque applications in severe environmental conditions.



Features:

Design - NEMA Standard MG-1, design B, ambient temperature of 40°C, altitude 1000M, temperature rise B.

Agency Listings and Standard - NEMA MG1, IEEE, IEC, DOE registered, NRCAN, CSAus and CSA Certified, CE and RoHS Compliant

Service Factor - 1.15

Electrical Supply - 3 phase, 230/460VAC, 575VAC @ 60 hz, 3 phase 190/380VAC @ 50 Hz rated to the next lower HP. (± 10% Voltage tolerance)

Windings - Highest quality Corona resistant, Inverter duty copper wire. VPI impregnated with additional dip and bake.

Efficiency - Integral HP models meet or exceed NEMA Premium efficiency levels.

Insulation - Class F insulation, with non-hygroscopic motor leads.

Bearings - Permanently Lubricated High quality Double Shielded Ball Bearings with oversized DE bearings. Lithium based grease operating temperature range – 25° through 175°C.

Enclosure Protection - IP55

Frame Construction - Rolled Steel with cast aluminum end shields.

Conduit Box - With ½ NPT knockouts positioned for wiring access every 90° with rubber gasket between box and motor frame.

Inverter Duty - Constant torque: 10/1 ratio, variable torque: 20/1 ratio

Nameplate - Stainless steel with etched details.

Drain Hole - Positioned in the stator frame at the lowest point, when motors are horizontally mounted.

Fan cover - Plastic fan & heavy duty plastic fan guard

Warranty - 1 year

100% CANADIAN OWNED



THREE PHASE ALL-IN-ONE 56HC AC MOTORS

HEAVY GAUGE ROLLED STEEL CONSTRUCTION

TEFC TOTALLY ENCLOSED FAN COOLED | ALL-IN-ONE FRAME 56HC



HP	RPM	VOLTS	FRAME	CAT NO.	NOM EFF.	F.L. AMPS	WT (Lbs)	"C" DIMENSION (Inch)	BRAKE KITS	BRAKE VOLTAGE	FT.LBS
0.33	1800	230/460	56HC	MQR-134CW	72	1.4/.7	22	12.38	A301	230/460	3
	1800	575	56HC	MPR-134CW	72	0.56	22	12.38	A297	575	3
	1200	230/460	56HC	MQR-136CW	63	2.38/1.18	24	12.38	A301	230/460	3
	1200	575	56HC	MPR-136CW	63	0.94	24	12.38	A297	575	3
0.50	1800	230/460	56HC	MQR-124CW	74	1.90/.95	24	12.38	A301	230/460	3
	1800	575	56HC	MPR-124CW	74	0.76	24	12.38	A297	575	3
	1200	230/460	56HC	MQR-126CW	68	2.6/1.3	25	12.38	A302	230/460	6
	1200	575	56HC	MPR-126CW	68	1.04	25	12.38	A298	575	6
0.75	1800	230/460	56HC	MQR-344CW	77	2.72/1.36	25.3	12.38	A302	230/460	6
	1800	575	56HC	MPR-344CW	77	1.09	25.3	12.38	A298	575	6
	1200	230/460	56HC	MQR-346CW	74	3.4/1.7	34	12.38	A302	230/460	6
	1200	575	56HC	MPR-346CW	74	1.36	34	12.38	A298	575	6
1	1800	230/460	56HC	MQRP-104CW	85.5	3.08/1.54	27	12.38	A302	230/460	6
	1800	575	56HC	MPRP-104CW	85.5	1.23	27	12.38	A298	575	6
	1200	230/460	56HC	MQRP-106CW	82.5	3.92/1.97	28	12.38	A303	230/460	10
	1200	575	56HC	MPRP-106CW	82.5	1.57	28	12.38	A299	575	10
1.5	1800	230/460	56HC	MQRP-154CW	86.5	4.45/2.23	31	12.38	A303	230/460	10
	1800	575	56HC	MPRP-154CW	86.5	1.78	31	12.38	A299	575	10
2	1800	230/460	56HC	MQRP-204CW	86.5	5.75/2.88	37	13.95	A303	230/460	10
	1800	575	56HC	MPRP-204CW	86.5	2.3	37	13.95	A299	575	10

